

Microblasting Equipment

MICROPEEN 950 ZP / ZPD

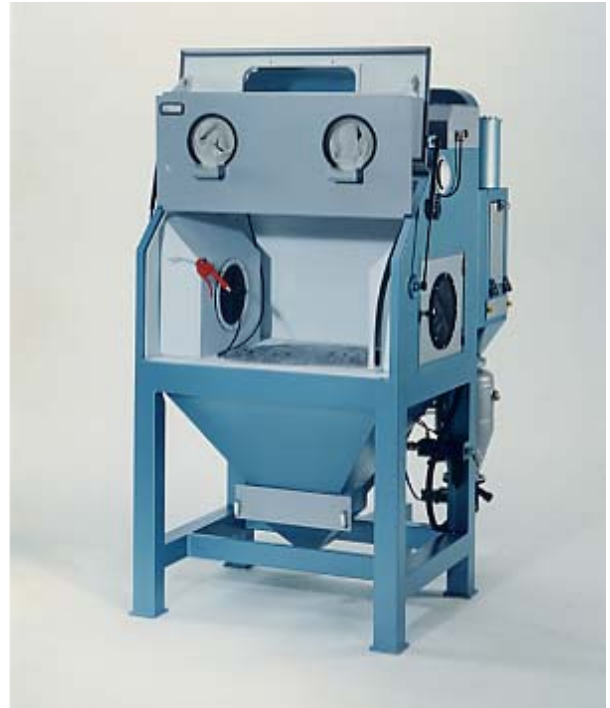

Standard equipment:

- Front flap door which is operated with cylinders actuated by compressed gas, with integrated sight window, provided with a safety glass and an attrition-proof glass in a quick change frame
- Side feeding doors, width 410 mm x height 220 mm or width 410 mm x height 320 mm (special), on the left and on the right side of the equipment, with double lamellar curtain
- Door interruption switch
- Working grate made of stable perforated plate, one-piece, detachable, diameter of holes 5 mm
- Padded sleeves and gloves, exchangeable
- Microblasting pistol unit, type EF 11, with a hard metal blasting nozzle, type HSD 5/10, with electric / pneumatic control system, setting range from 0 - 10 bar, adjustable via pressure reducing valve, microblasting pressure reading on the manometer
- Automatic working pressure blasting tank
- Automatic, selective recycling of microblasting agent by high-performance cyclone
- Built-in high surface micro filter system, containing two filter cartridges with 2 m² filter surface each. Automatic pneumatic filter cleaning with time intervals
- Dust collector, made of steel, complete with packing
- Ventilator for high surface micro filter system, electronically continuously variable
- Blow-out pistol (air-blasting pistol)
- Foot actuated switch with impulse contact
- Compressed-air connection at equipment 1/2" G, including oil and water separator
- Control panel with all necessary switches and control elements
- Key-operated switch, on / off, with 2 keys

Optional accessories:

(on request)

- Rotary table unit, made of aluminium or steel, Ø 600 mm, manually rotatable
- Fitting out of both side feeding doors, left and right, with feeding boxes and integrated rubber lined connecting passages, for the cleaning of screws
- Supporting roller brackets with plastic rollers
- Hour counter of microblasting time

Sales / Development

iepco ag
Hofstrasse 21
CH-8181 Höri
Phone +41 / (0)44 861 16 16
Fax +41 / (0)44 860 63 86
www.iepco.ch

Production Plant

iepco ag
Steiächerweg 10
CH-5316 Leuggern
Phone +41 / (0)56 268 80 40
Fax +41 / (0)56 268 80 50
info@iepco.ch

Technologies for
perfect surfaces

Microblasting Equipment

MICROPEEN 950 ZP / ZPD

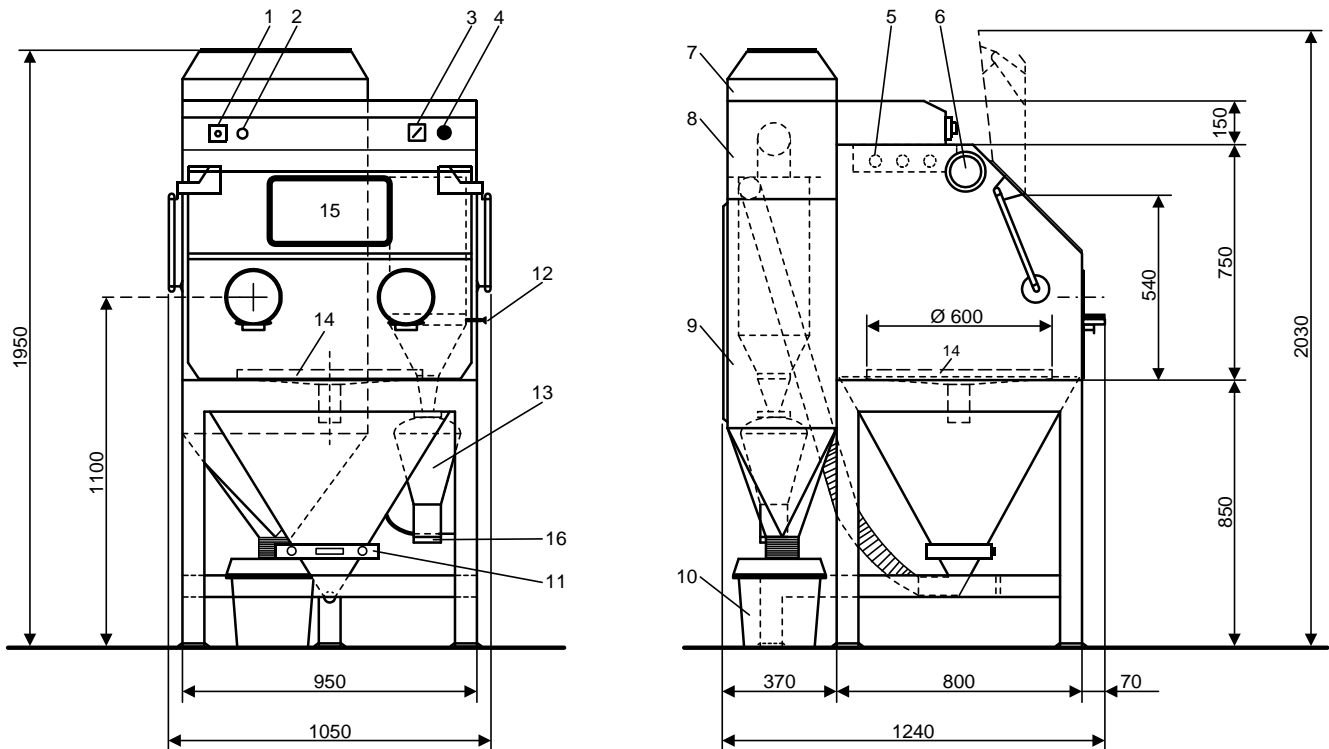

Legend:

- | | |
|------------------------------------|---|
| 1 Key-operated switch | 9 Filter |
| 2 Control safety | 10 Dust collector |
| 3 Manometer | 11 Impurity collecting drawer, 1. step |
| 4 Pressure regulator | 12 Impurity collecting drawer, 2. step |
| 5 Illumination, 3 x 18 Watt | 13 Pressure blasting tank |
| 6 Adjustable air inlet filter caps | 14 Rotary table, Ø 600 mm |
| 7 Ventilator | 15 Safety and attrition glass |
| 8 Filter cleaning | 16 Microblasting agent dosing station
(Pos. 14 only on request as an optional accessory) |

Usable space:

Width 940 x depth 750 x height 540 mm.
Optimal for the surface treatment of workpieces with the dimension of width 750 x depth 750 x height 300 mm

Operating voltage:

230 V + PE / 50/60 Hz

Power consumption:

460 W

Control safety:

3,0 A

Compressed air connection:

On the side of the building 3/4" G
On the side of the equipment 1/2" G
Pressure max. 10 bar

Sound level:

72 dB(A) without microblasting
75 dB(A) with microblasting with 3 bar

Weight:

415 kg

All data are given without liability on our part. We reserve the right to modify constructional design at any time.

Sales / Development

iepcO ag
Hofstrasse 21
CH-8181 Höri
Phone +41 / (0)44 861 16 16
Fax +41 / (0)44 860 63 86
www.iepcO.ch

Production Plant

iepcO ag
Steiächerweg 10
CH-5316 Leuggern
Phone +41 / (0)56 268 80 40
Fax +41 / (0)56 268 80 50
info@iepcO.ch