

Microblasting Equipment PEENMATIC 1100 ZFA



Standard equipment:

- Conveyor drive through the microblasting equipment
- Sight window with a safety glass and an attrition-proof glass
- Three microblasting pistol units, type EF-A 4, with hard metal blasting nozzle HSD 6/15 Lavall, pressure reducing valve and manometer, 0 - 10 bar
- Microblasting agent pre-accelerating system with moving injector, with electro-pneumatic control system, pressure reducing valve and manometer, setting range from 0 to 4 bar
- Automatic, selective recycling of microblasting agent by high-performance cyclone
- Compressed-air connection at equipment 1/2" G
- Oil and water separator
- Separately placed control box, slewable, with separate arranged electric, electronic and pneumatic control systems as well as all the necessary operating and control elements
- Separately installed high surface microfilter unit, type IMF-3, ventilator electronically continuously adjustable, with automatic, electro-pneumatic filter cleaning
- Dust collector, moveable

Sales / Development

iepco ag
Hofstrasse 21
CH-8181 Höri
Phone +41 / (0)44 861 16 16
Fax +41 / (0)44 860 63 86
www.iepco.ch

Production Plant

iepco ag
Steiächerweg 10
CH-5316 Leuggern
Phone +41 / (0)56 268 80 40
Fax +41 / (0)56 268 80 50
info@iepco.ch

Technologies for
perfect surfaces

Microblasting Equipment PEENMATIC 1100 ZFA

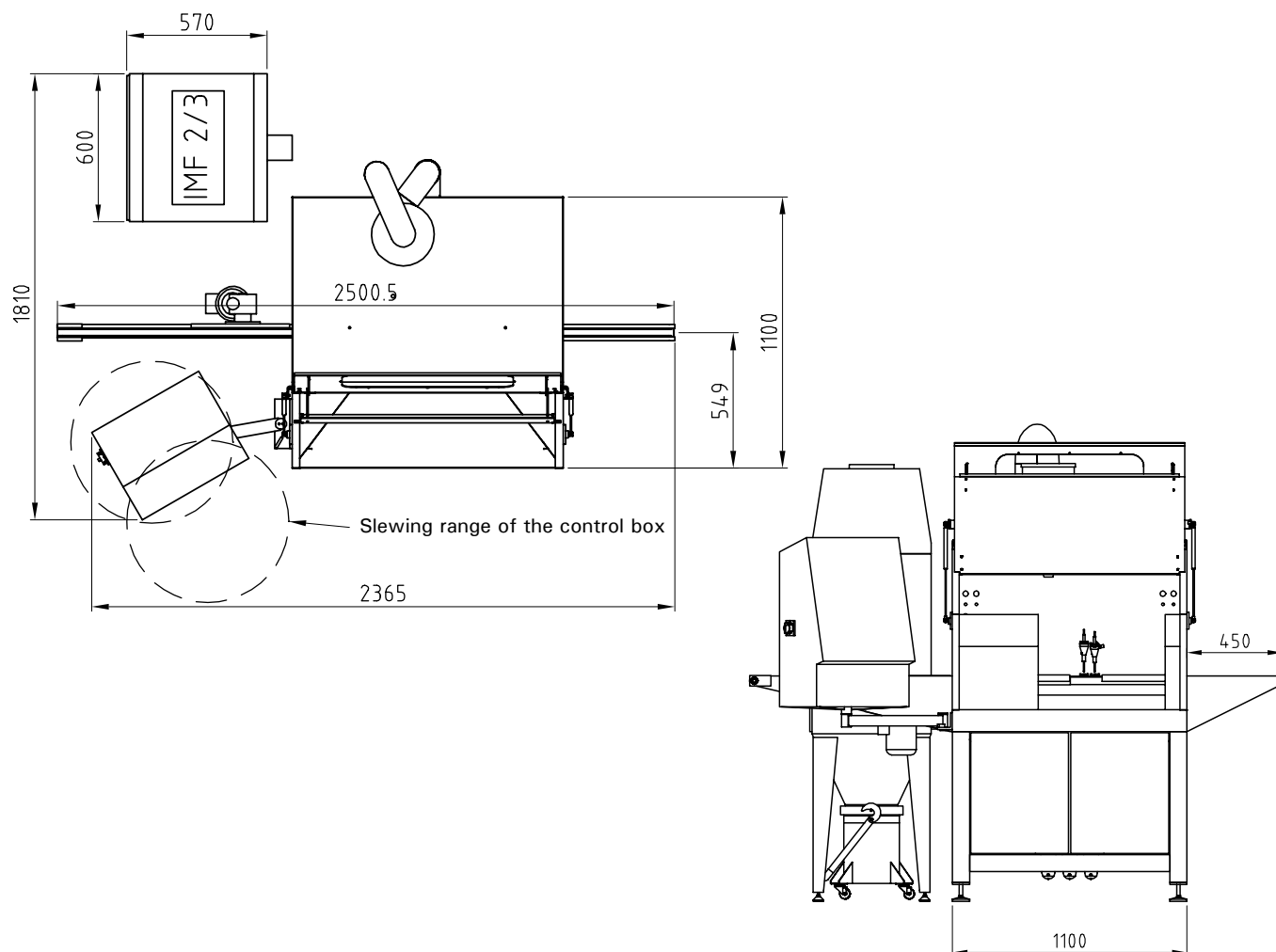

Microblasting equipment:	Width 2'510 x depth 1'810 x height 2'300 mm
Operating voltage:	3 x 400 V + N + PE / 50 Hz
Power consumption:	0,75 kW, including microfilter unit
Automatic circuit breaker:	3 x 10 ampere
Illumination:	3 x 18 W
Compressed air connection:	On the side of the building 3/4" G On the side of the equipment 1/2" G Pressure 0 - 10 bar
Sound level:	85 - 90 dB(A) without microblasting, with blowing-off Over 90 dB(A) with microblasting with 3 bar and with blowing-off
Weight:	approx. 375 kg

All data are given without liability on our part. We reserve the right to modify constructional design at any time.

Sales / Development

iepcO ag
Hofstrasse 21
CH-8181 Höri
Phone +41 / (0)44 861 16 16
Fax +41 / (0)44 860 63 86
www.iepcO.ch

Production Plant

iepcO ag
Steiächerweg 10
CH-5316 Leuggern
Phone +41 / (0)56 268 80 40
Fax +41 / (0)56 268 80 50
info@iepcO.ch