

# Microblasting Equipment

## PEENMATIC 1500 ZDA-4



### Standard equipment:

- This automatic working microblasting equipment has two separated microblasting chambers with each two rotary cage units in which precision small parts can be microblasted. For each microblasting chamber the microblasting parameters with one microblasting agent each can be differently adjusted
- Two tilting doors for a fast feeding and taking out of small parts from the rotary cage
- There are each two microblasting pistols at easily adjustable holding devices installed in both microblasting chambers
- This 4 microblasting pistol units are each time equipped with one hard metal blasting nozzle HSD 5/10 or with one hard metal blasting nozzle HSD 6/15 Lavall, adjustable via pressure reducing valve, 0 - 10 bar, microblasting pressure reading on the manometer
- Every microblasting chamber has one blowing-off device with two blowing-off nozzles each, which blows off the rotary cage during a certain time after the microblasting operation
- Microblasting agent pre-accelerating system with moving injector, adjustable via pressure reducing valve, 0 - 4 bar, pressure reading on the manometer
- Automatic, selective recycling of microblasting agent by high-performance cyclone
- Service doors with integrated sight windows, provided with a safety glass and an attrition-proof glass, on both sides of the microblasting equipment
- 2 drying systems for microblasting agents, each 50 W, electronically continuously variable
- Control box with all necessary electric, electronic and pneumatic control devices as well as with all operating and control elements
- Separately installed high surface microfilter unit, type IMF-3, ventilator electronically continuously adjustable, with automatic, electro-pneumatic filter cleaning, including integrated dust collector, moveable
- The microfilter unit is connected with a flexible dust extraction hose with the microblasting equipment
- Compressed-air connection, 3/4", at equipment
- Oil and water separator

### Sales / Development

iepco ag  
Hofstrasse 21  
CH-8181 Höri  
Phone +41 / (0)44 861 16 16  
Fax +41 / (0)44 860 63 86  
www.iepco.ch

### Production Plant

iepco ag  
Steiächerweg 10  
CH-5316 Leuggern  
Phone +41 / (0)56 268 80 40  
Fax +41 / (0)56 268 80 50  
info@iepco.ch

Technologies for  
perfect surfaces

# Microblasting Equipment PEENMATIC 1500 ZDA-4

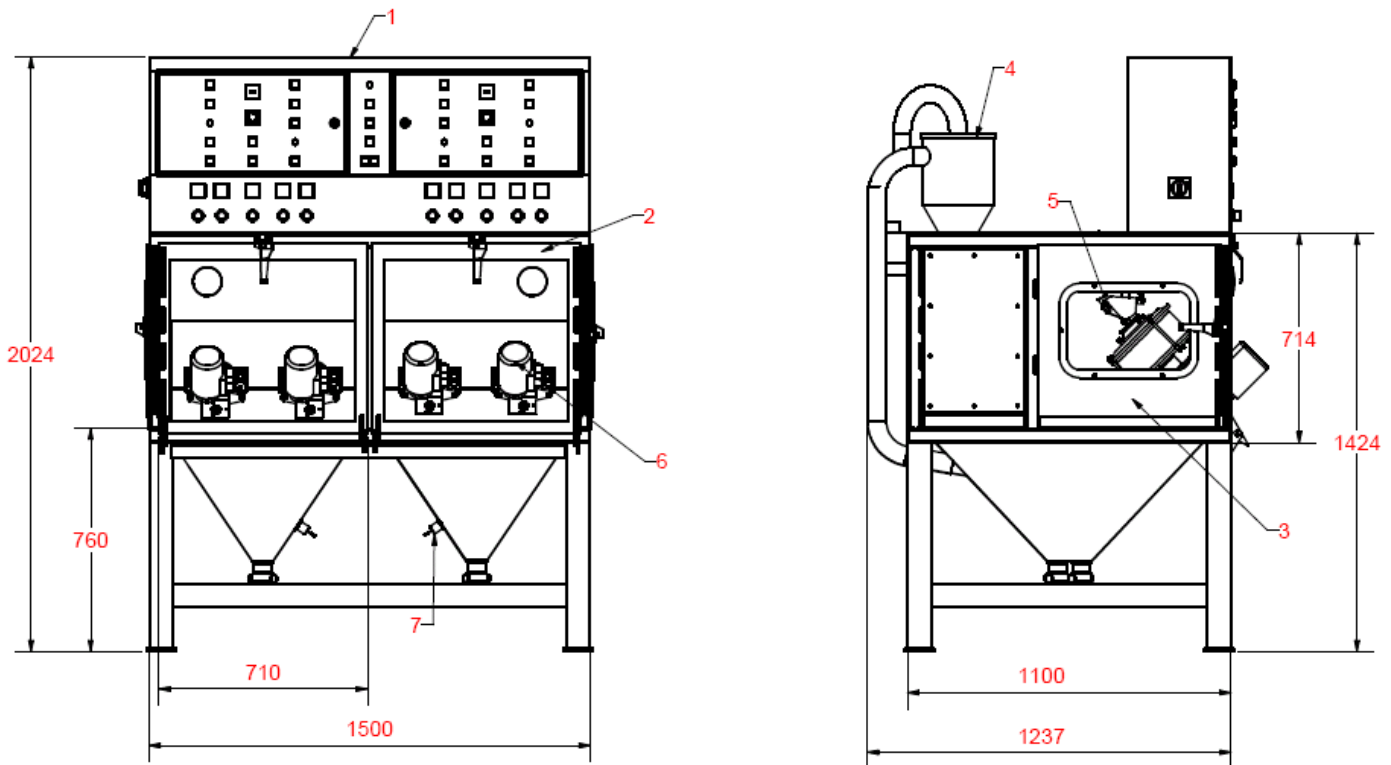

## Legend:

- |   |   |
|---|---|
| 1 Control box                                 | 4 Cyclone                                   |
| 2 Front flap doors                            | 5 Holding devices for microblasting pistols |
| 3 Service doors with integrated sight windows | 6 Rotary drive units for rotary cages       |
| 7 Sensors for microblasting agents            |   |

## Dimensions:

Width 1'500 x depth 1'100 x height 2'025 mm.

## Workspace per chamber:

Width 675 x depth 600 x height 660 mm

## Sizes of rotary cages:

Ø 150 - 300 mm, height max. 200 mm

## Operating voltage:

3 x 400 V + PE / 50/60 Hz

## Power consumption:

460 W

## Control safety:

3,0 AT

## Compressed-air connection:

On the side of the building	3/4" G
On the side of the equipment	1/2" G
Pressure	max. 10 bar

## Sound level:

72 dB(A) without microblasting  
75 dB(A) with microblasting at 3 bar

## Weight:

520 kg

All data are given without liability on our part. We reserve the right to modify constructional design at any time.

## Sales / Development

iepcO ag  
Hofstrasse 21  
CH-8181 Höri  
Phone +41 / (0)44 861 16 16  
Fax +41 / (0)44 860 63 86  
www.iepcO.ch

## Production Plant

iepcO ag  
Steiächerweg 10  
CH-5316 Leuggern  
Phone +41 / (0)56 268 80 40  
Fax +41 / (0)56 268 80 50  
info@iepcO.ch