

# Microblasting Equipment PEENMATIC 2500 ZIDA



## Description of equipment

The PEENMATIC 2500 ZIDA is an automatic microblasting equipment for the defined, automatic microblasting of cylinder surfaces with a maximum diameter of 250 mm and a maximum length of 1'800 mm.

- Standard equipment:**
- Front flap door which is operated with pneumatic cylinders for simple opening and closing. With three integrated sight windows, provided each with a safety glass and an attrition-proof glass in a quick change frame
  - 4 microblasting pistol units, type EF 4, with a hard metal blasting nozzle HSD 6/15 Lavall each, for extensive microblasting, adjustable via pressure reducing valve, 0 - 8 bar, microblasting pressure reading on the manometer
  - All necessary microblasting pistol devices and connecting tubes
  - Microblasting agent pre-accelerating system with moving injector, adjustable via pressure reducing valve, 0 - 4 bar, pressure reading on the manometer
  - Automatic, selective recycling of microblasting agent by two high-performance cyclones
  - Pneumatic cyclone flaps
  - 2 separately installed high surface microfilter units, type IMF-3, ventilator electronically continuously adjustable, with automatic, electro-pneumatic filter cleaning. Including integrated dust collector, moveable
  - Laterally attached blow-out pistol (air-blasting pistol) with spiral coiled tube, allowing taking out workpieces almost dustless
  - Microblasting agent level monitoring by means of a sensor
  - Separately placed control box, built-on on the right side of the microblasting equipment on a swinging arm, with separate arranged electric, electronic and pneumatic control systems as well as all the necessary operating and control elements
  - Main switch, on / off
  - Illumination, 2 x 36 W

### Sales / Development

iepcO ag  
Hofstrasse 21  
CH-8181 Höri  
Phone +41 / (0)44 861 16 16  
Fax +41 / (0)44 860 63 86  
www.iepcO.ch

### Production Plant

iepcO ag  
Steiächerweg 10  
CH-5316 Leuggern  
Phone +41 / (0)56 268 80 40  
Fax +41 / (0)56 268 80 50  
info@iepcO.ch

Technologies for  
perfect surfaces

# Microblasting Equipment PEENMATIC 2500 ZIDA

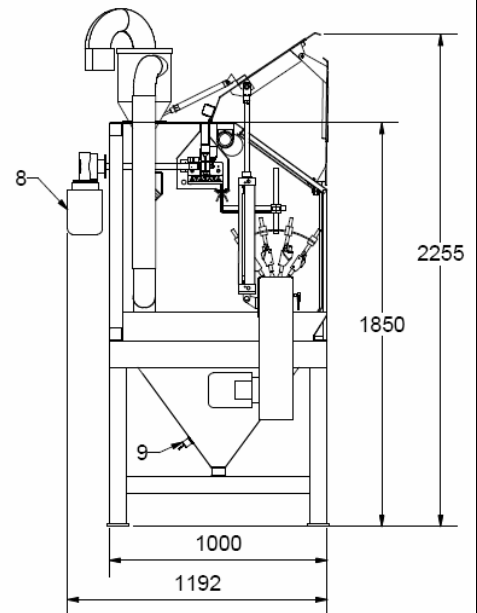
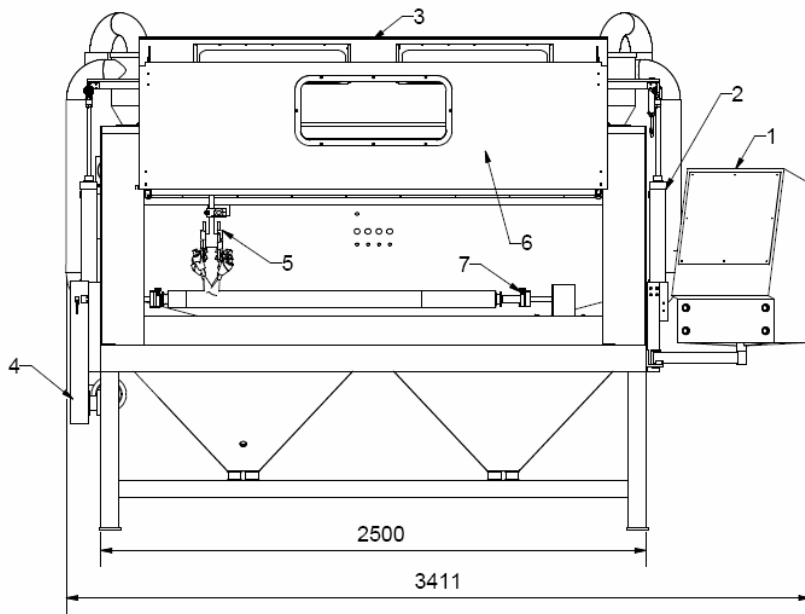

## Legend:

- |  |  |
|--|--|
| 1 Control box  | 6 Machine illumination                 |
| 2 Pneumatic cylinder   | 7 Receiver for cylinders               |
| 3 Front flap door with sight windows                                       | 8 Drive for microblasting pistol unit  |
| 4 Cylinder drive   | 9 Microblasting agent level monitoring |
| 5 Special microblasting pistol holding device with 4 microblasting pistols | 10 High-performance cyclone            |

## Usable space:

Width 2'000 x depth 950 x height 500 mm.  
Optimal for the surface treatment of cylinders with a maximum diameter of 250 mm and a maximum length of 1'800 mm.

## Operating voltage:

3 x 400 V + N + PE / 50/60 Hz

## Power consumption:

1,4 kW

## Control safety:

6 A

## Compressed air connection:

On the side of the building	1" G
On the side of the equipment	3/4" G
Pressure	0 - 10 bar

## Sound level:

72 dB(A) without microblasting  
75 dB(A) with microblasting with 3 bar

## Weight:

500 kg

All data are given without liability on our part. We reserve the right to modify constructional design at any time.

### Sales / Development

iepcO ag  
Hofstrasse 21  
CH-8181 Höri  
Phone +41 / (0)44 861 16 16  
Fax +41 / (0)44 860 63 86  
www.iepcO.ch

### Production Plant

iepcO ag  
Steiächerweg 10  
CH-5316 Leuggern  
Phone +41 / (0)56 268 80 40  
Fax +41 / (0)56 268 80 50  
info@iepcO.ch