

Microblasting Equipment PEENMATIC 770S



- Standard equipment:**
- Front flap door which is operated with cylinders, supported by compressed gas, can be opened up to the working height of the microblasting equipment, with integrated sight window with a safety and an attrition-proof glass (double glass) in a quick change frame
 - Side feeding doors, width 360 x height 290 mm, on the left and on the right side of the equipment
 - Door interruption switch
 - Manual, hydraulic adjustment of height (maintenance-free)
 - 2-feet system with built-in rollers, moveable, can be locked manually
 - Working grate made of perforated plate, two-piece, detachable, diameter of holes 5 mm
 - Padded sleeves and gloves, exchangeable
 - Microblasting pistol unit, type EF 3, with hard metal blasting nozzle HSD 5/10, adjustable via pressure reducing valve, 0 - 8,5 bar, microblasting pressure reading on the manometer
 - Holding device for microblasting pistol with swinging arm, height 115 mm, swivelling range 275 mm, universally adjustable
 - Continuous drying system for microblasting agents, 50 W, electronically continuously adjustable, including covering for heating element
 - Microblasting agent pre-accelerating system with moving injector, adjustable via pressure reduction valve, 0 - 4 bar, pressure reading on the manometer
 - Automatic selective microblasting agent recycling system, type SHOT SEPARATOR
 - Built-in high surface microfilter system with one filter cartridge with 1,00 m² filter surface. Automatic, electro-pneumatic filter cleaning
 - Dust collector, made of steel
 - Ventilator for high surface microfilter unit, electronically continuously variable
 - Blow-out pistol (air-blasting pistol)
 - Foot actuated switch with impulse contact
 - Compressed-air connection, 1/4", at equipment, including oil and water separator
 - Control panel with all necessary switches and control elements
 - Key-operated switch, on / off, with 2 keys
 - Illumination, 2 x 18 W
- Accessories:**
- (on request)
- Built-in rotary table unit, Ø 350 mm, made of aluminium, manually rotatable, for workpieces up to a maximum of 50 kg
 - Equipping the side feeding doors, left and right, with feeding boxes and integrated rubber lined connecting passages, for the treatment of screws
 - Hour counter of microblasting time

Sales / Development
iepcO ag
Hofstrasse 21
CH-8181 Höri
Phone +41 / (0)44 861 16 16
Fax +41 / (0)44 860 63 86
www.iepcO.ch

Production Plant
iepcO ag
Steiächerweg 10
CH-5316 Leuggern
Phone +41 / (0)56 268 80 40
Fax +41 / (0)56 268 80 50
info@iepcO.ch

Technologies for
perfect surfaces

Microblasting Equipment PEENMATIC 770S

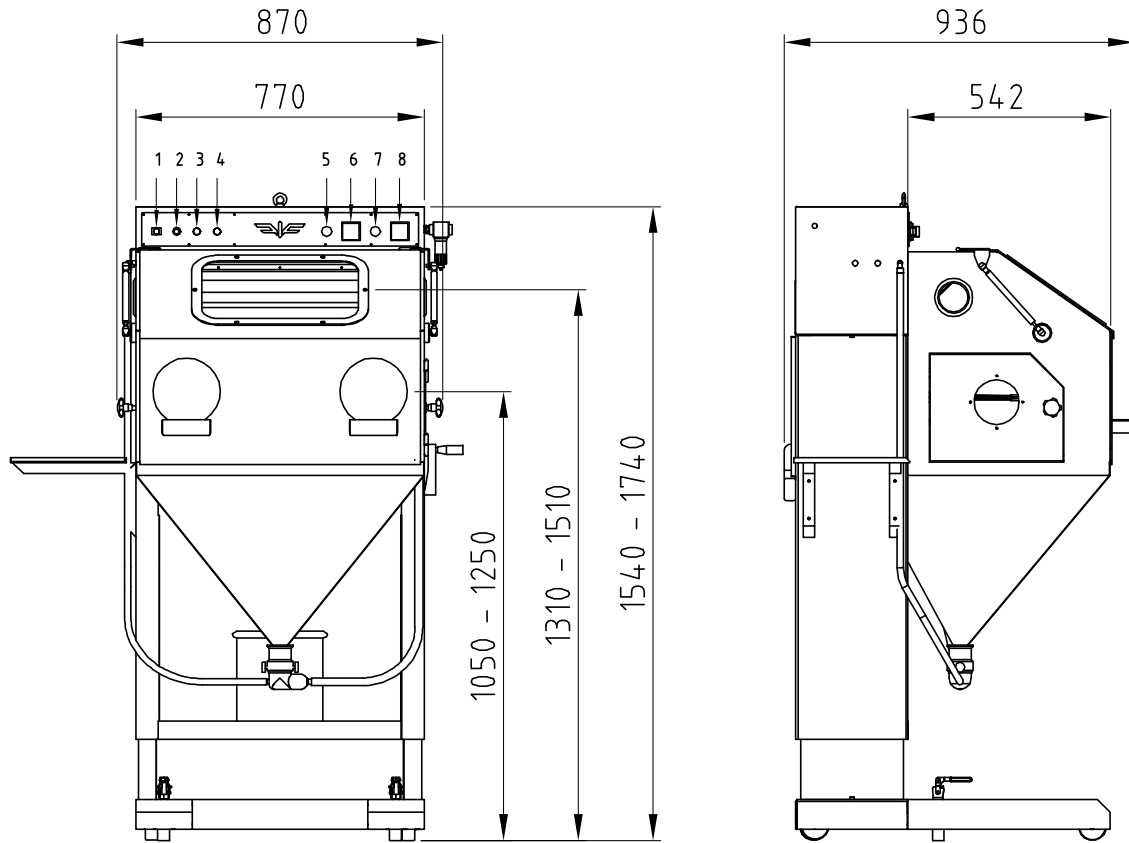

Legend:

- | | | | |
|---|---|---|---|
| 1 | Main switch | 5 | Pressure regulator for moving injector |
| 2 | Control safety | 6 | Manometer for moving injector |
| 3 | Potentiometer for ventilator | 7 | Pressure regulator for microblasting pistol |
| 4 | Potentiometer for microblasting agent drying system | 8 | Manometer for microblasting pistol |

Usable space:

Width 740 x depth 520 x height 500 mm.
Optimal for surface treatment of workpieces with dimensions of width 500 x depth 400 x height 250 mm

Operating voltage:

230 V + PE / 50/60 Hz

Power consumption:

150 W

Control safety:

4 AT

Compressed-air connection:

On the side of the building	1/2" G
On the side of the equipment	1/4" G
Pressure	0 - 10 bar

Sound level:

58 dB(A) without microblasting
65 dB(A) with microblasting at 3 bar

Weight:

205 kg

All data are given without liability on our part. We reserve the right to modify constructional design at any time.

Sales / Development

iepcO ag
Hofstrasse 21
CH-8181 Höri
Phone +41 / (0)44 861 16 16
Fax +41 / (0)44 860 63 86
www.iepcO.ch

Production Plant

iepcO ag
Steiächerweg 10
CH-5316 Leuggern
Phone +41 / (0)56 268 80 40
Fax +41 / (0)56 268 80 50
info@iepcO.ch