

# Microblasting Equipment PEENMATIC 950 ZIDA



- Standard equipment:**
- This automatically working microblasting equipment is provided with an automatically controlled rotary table unit, Ø 800 mm, for the transport of flat small parts through the microblasting equipment. The parts will be microblasted from above with 3 horizontal / radial movable microblasting pistols. Small and mass production parts can be cleaned, deburred, structured and densificated (silk matt polished) in a fast and efficient way
  - Blowing-off device, allowing to take out workpieces almost dustless
  - Special front flap door which is operated with cylinders actuated by compressed gas, with integrated sight window, provided with a safety glass and an attrition-proof glass in a quick change frame
  - Microblasting pistol units, type EF-A 4, complete, with hard metal blasting nozzle HSD 8/15, adjustable via pressure reducing valve, 0 - 8,5 bar, microblasting pressure reading on the manometer
  - Microblasting agent pre-accelerating system with moving injector, adjustable via pressure reducing valve, 0 - 4 bar, pressure reading on the manometer
  - Automatic, selective recycling of microblasting agent by high-performance cyclone
  - Microblasting agent tank, installed at the back right, designed for 3 moving injectors
  - Drying system for microblasting agents
  - Microblasting agent level monitoring with by means of a sensor
  - Key-operated switch, on / off, with 2 keys
  - Built-in high-surface microfilter system, containing two filter cartridges with 2 m<sup>2</sup> surface each. Automatic pneumatic filter cleaning with time intervals
  - Dust collector, made of steel

## Sales / Development

iepco ag  
Hofstrasse 21  
CH-8181 Höri  
Phone +41 / (0)44 861 16 16  
Fax +41 / (0)44 860 63 86  
www.iepco.ch

## Production Plant

iepco ag  
Steiächerweg 10  
CH-5316 Leuggern  
Phone +41 / (0)56 268 80 40  
Fax +41 / (0)56 268 80 50  
info@iepco.ch

Technologies for  
perfect surfaces

# Microblasting Equipment PEENMATIC 950 ZIDA

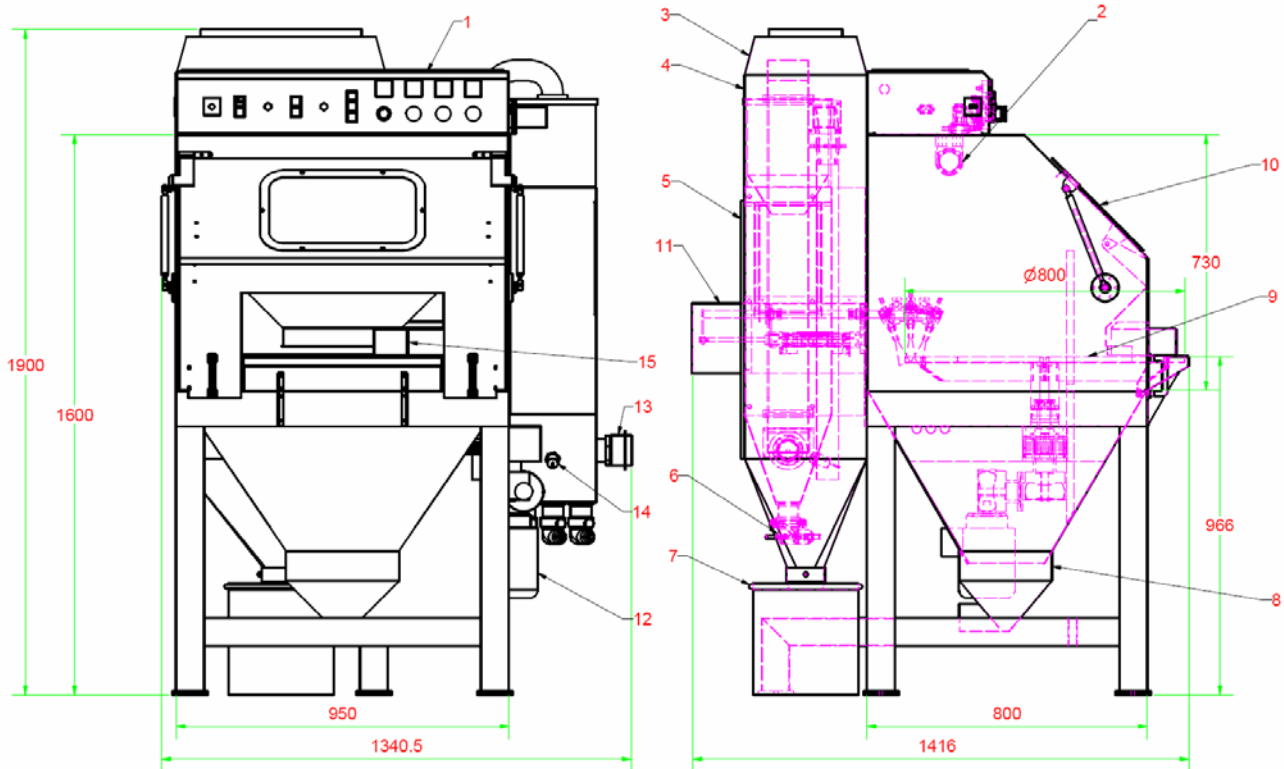

## Legend:

- |                              |   |
|------------------------------|---|
| 1 Control box                | 9 Rotary table, Ø 800 mm                  |
| 2 Illumination, 1 x 36 Watt  | 10 Safety and attrition glass             |
| 3 Ventilator                 | 11 Microblasting pistol lifting device    |
| 4 Filter cleaning            | 12 Gear motor                             |
| 5 Filter                     | 13 Drying system for microblasting agents |
| 6 Moving injector            | 14 Microblasting agent sensor             |
| 7 Dust collector             | 15 Blowing-off box                        |
| 8 Impurity collecting drawer |   |

## Usable space:

Rotary table, Ø 800 mm outside, Ø 500 mm inside.  
Optimal for the surface treatment of workpieces with the dimension of width 150 x depth 130 x height 10 mm

## Operating voltage:

230 V + P + N + PE / 50/60 Hz

## Power consumption:

750 W

## Control safety:

6,0 A

## Compressed air connection:

On the side of the building	3/4" G
On the side of the equipment	1/2" G
Pressure	max. 10 bar

## Sound level:

72 dB(A) without microblasting  
85 dB(A) with microblasting with 3 bar

## Weight:

430 kg

All data are given without liability on our part. We reserve the right to modify constructional design at any time.

### Sales / Development

iepcO ag  
Hofstrasse 21  
CH-8181 Höri  
Phone +41 / (0)44 861 16 16  
Fax +41 / (0)44 860 63 86  
www.iepcO.ch

### Production Plant

iepcO ag  
Steiächerweg 10  
CH-5316 Leuggern  
Phone +41 / (0)56 268 80 40  
Fax +41 / (0)56 268 80 50  
info@iepcO.ch